

Si-SiC reticulated macroporous foams: processing, properties, and applications

Alberto Ortona, Simone Pusterla, Claudio D'Angelo, Maurizio Barbato
SUPSI, The iCIMSI Research Institute, Manno, Switzerland

Sandro Gianella, Daniele Gaia
Erbicol, Balerna, Switzerland

MATERIALS CHALLENGES IN
ALTERNATIVE & RENEWABLE ENERGY

February 26–March 1, 2012

Hilton Clearwater Beach Resort | Clearwater, FL USA



Outline

- Si SiC foams
- Si SiC foams applications
- Foams effective properties

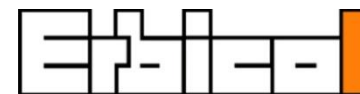

Outline

- Si SiC foams
- Si SiC foams applications
 - Porous Burners
 - Reformers
 - Solar absorbers
- Foams effective properties

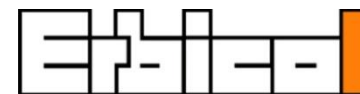

- Si SiC foams
- Si SiC foams applications
 - Porous Burners
 - Reformers
 - Solar absorbers
- Foams effective properties
 - Heat flow by conduction
 - Heat flow by convection

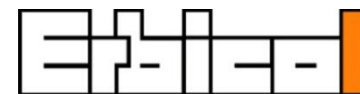

Concentrating thermal solar power

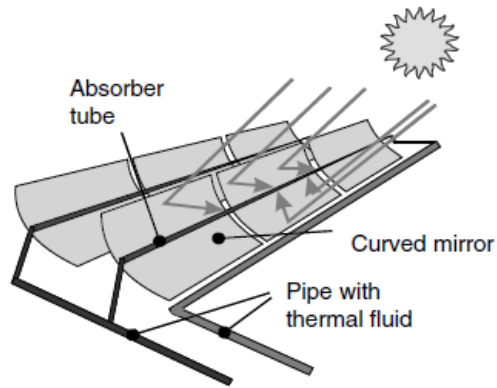

Parabolic trough

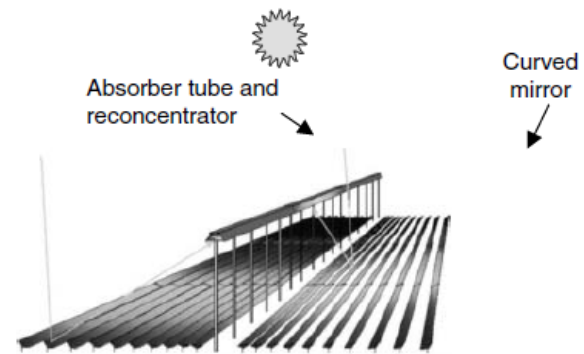

Linear fresnel

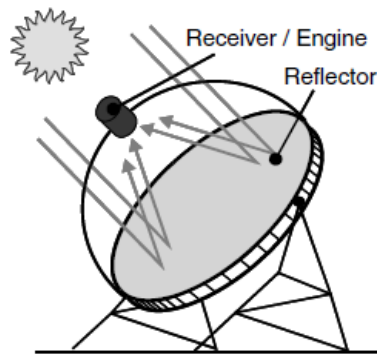

Dish/Engine

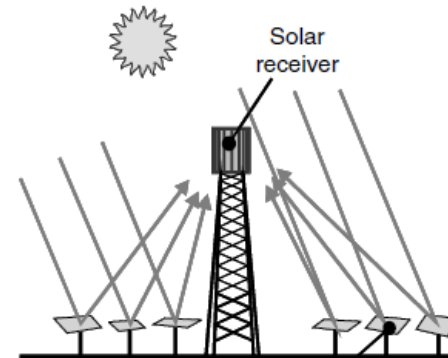

Central receiver

Manuel Romero, Eduardo Zarza, Concentrating solar thermal power, www.solarpaces.org

$$\eta_{\text{rec}} = \alpha - \sigma \varepsilon \frac{(T_{\text{abs}}^4 - T_{\text{amb}}^4)}{C\phi}$$

Concentrating thermal solar power

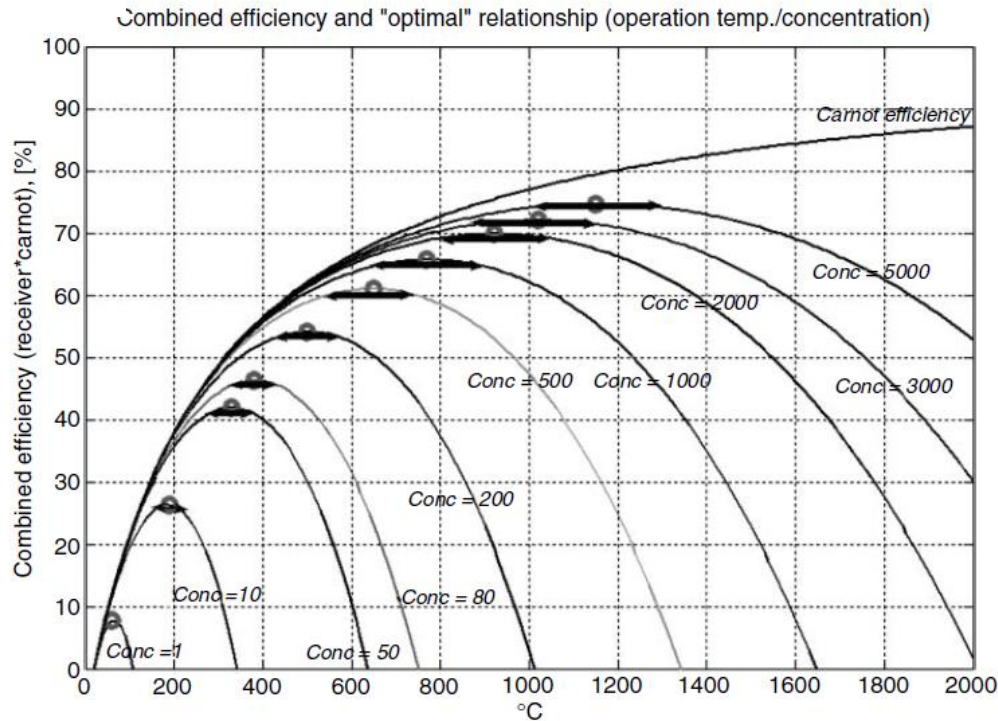

Combined efficiency of the solar receiver/heat engine system for different solar concentration factors and operation temperatures of the absorber.
 Direct normal irradiance of 770 W/m², ambient temperature of 20°C,

Manuel Romero, Eduardo Zarza, Concentrating solar thermal power, www.solarpaces.org

Concentrating thermal solar power

Table 1 Characteristics of solar thermal power central receiver systems, adapted from [6]

| | |
|-----------------------------|---|
| Typical Size | 10–200 MW* |
| Operating Temperature | |
| - Rankine | 565°C |
| - Brayton | 800°C |
| Annual Capacity Factor | 20–77%* |
| Peak Efficiency | 16–23%* |
| Annual Net Efficiency | 12–20%* |
| Commercial Status | Scale-Up Demonstration (10–30 MW) |
| Technology Development Risk | Medium |
| Storage available | Nitrate salt for molten salt receivers Ceramic bed for air receivers |
| Hybrid designs | Yes |
| Investment cost | |
| $\$. W^{-1}$ | 4.4–2.5* |
| $\$. W_p^{-1**}$ | 2.4–0.9* |

*Values indicate changes over the 1997–2030 time frame.

** $\$. W_p^{-1}$ removes the effect of energy storage or solar multiple, as usually made in PV.

(In the present study a conversion rate of 1 Euro=0.91 \$ as of September 2001 has been used)

Manuel Romero, Eduardo Zarza, Concentrating solar thermal power, www.solarpaces.org

Si-SiC cellular ceramics



Avizo™

vsg
Visualization Sciences Group

Si-SiC cellular application

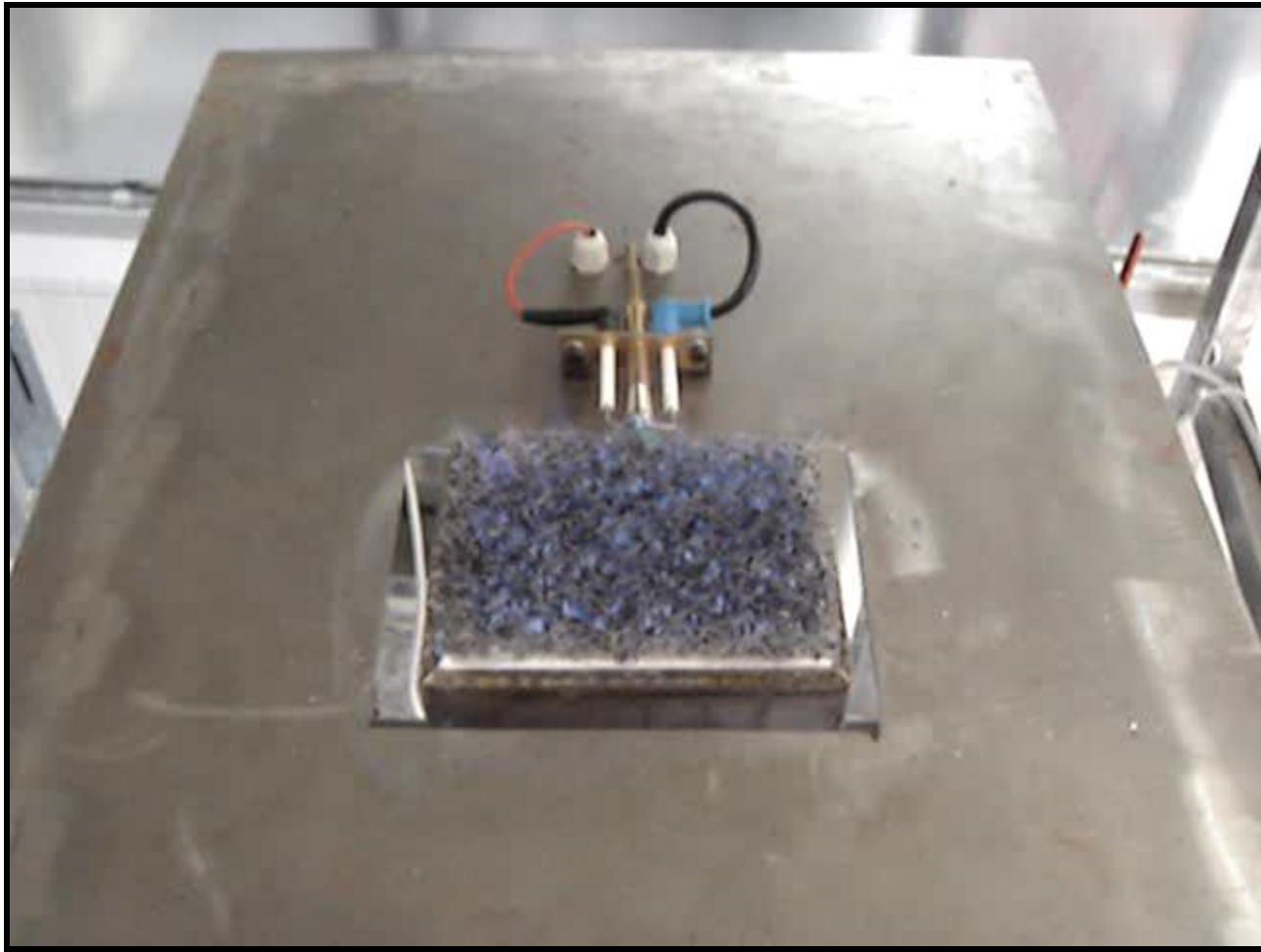

Why Si-SiC?

| | Si-SiC | Alumina | Yttria-Stabilized Zirconia | Glassy Carbon |
|---|---------------|----------------|---------------------------------------|--------------------------|
| Density [g/cc] | 2.83 | 3.96 | 6.02 | 1.5 |
| Flexural stress [Mpa] | 203 | 350 | 1240 | 200 |
| Young's modulus [Gpa] | 264 | 340 | 210 | 30 |
| CTE, linear (@RT) [$\mu\text{m}/\text{m}\cdot\text{K}$] | 4.30 | 5.50 | 10.30 | 3.50 |
| Specific heat capacity (@RT) [J/g-K] | 0.94 | 0.75 | 0.40 | 0.50 |
| Thermal Conductivity (@RT) [W/m-K] | 85.10 | 46.00 | 2.20 | 4.60 |
| Maximum Service Temperature, Air $^{\circ}\text{C}$ | 1450 | 1750 | 1500 | 500 |

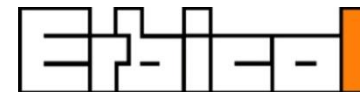

Porous Burners

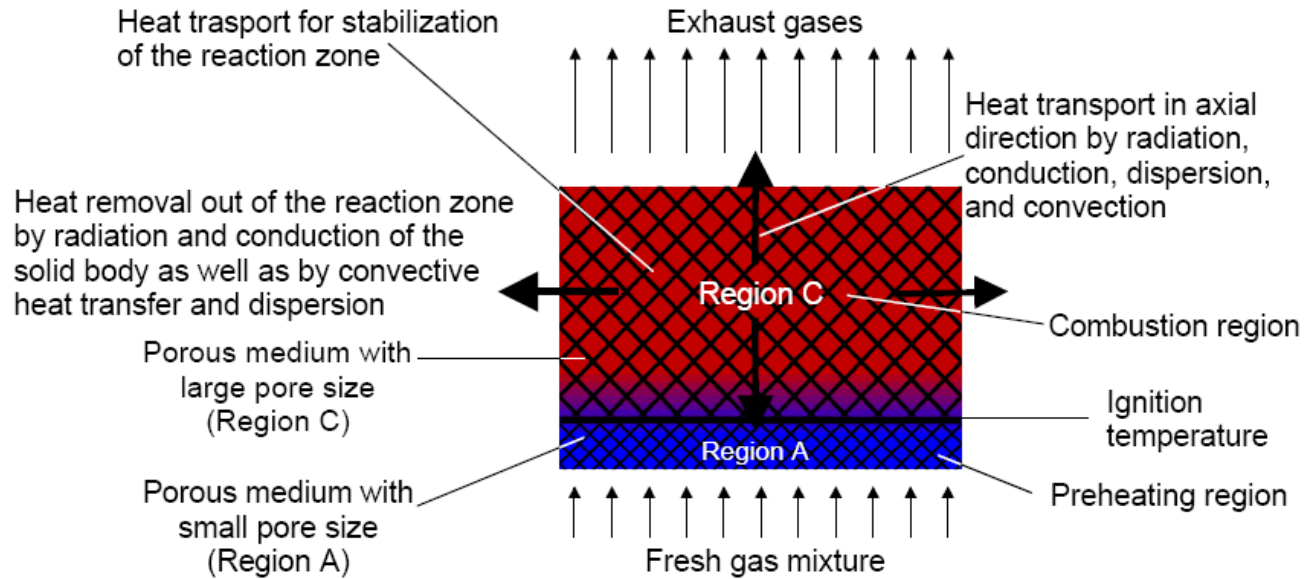

D. Trims, F. Durst, Combustion in porous medium - advances and applications, Combust. Sci. Technol., 121, 153-168 ,1996.

| | | | | | |
|---|---|---|---|---|---|
| |  |  |  |  |  |
| Typ | Katalytstrahler | Keramikstrahler | Metallfaserstrahler gestrickte Oberfläche | Metallfaserstrahler gesinterte Oberfläche | Porenstrahler |
| Art | Langwelliger Strahler | Mittelwelliger Strahler | Mittelwelliger Strahler | Mittelwelliger Strahler | Kurzwelliger Strahler |
| Wellenlänge | 3,3 - 5 μm | 2,4 μm | 2,2 μm | 2,2 μm | 1,7 μm |
| Max. Strahlertemperatur | 600 °C | 950 °C | 1050 °C | 1050 °C | 1450 °C |
| Max. thermische Flächenbelastung | 30 kW/m ² | 120 kW/m ² | 200 kW/m ² | 250 kW/m ² | 1000 kW/m ² |

(Source GOGAS web site)

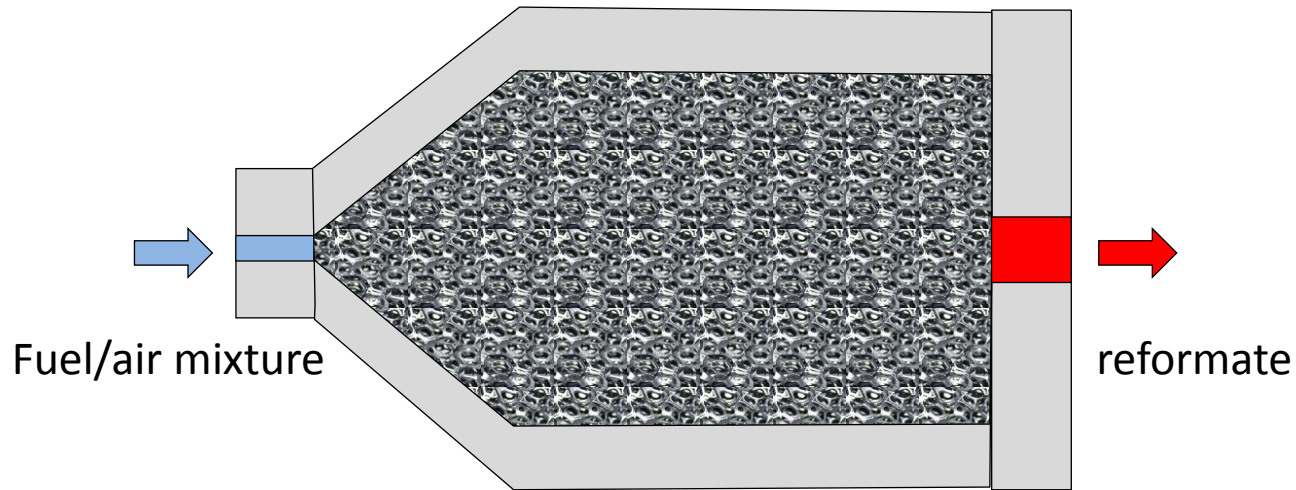

Compared with the other reforming technologies the exothermic thermal process has no need for external heat sources and additional feeds like water as in steam reforming. The process is catalyst free avoiding catalyst deactivation

Z. Al-Hamamre, S. Voß, D. Trimis, international journal of hydrogen energy 34 (2009) 827–832

S. Voss, D. Trimis, J. Valldorf,, 18th World Hydrogen Energy Conference 2010 - WHEC 2010, Parallel Sessions Book 6: Stationary Applications / Transportation Applications, 2010, Essen

Concentrated solar radiation absorbers

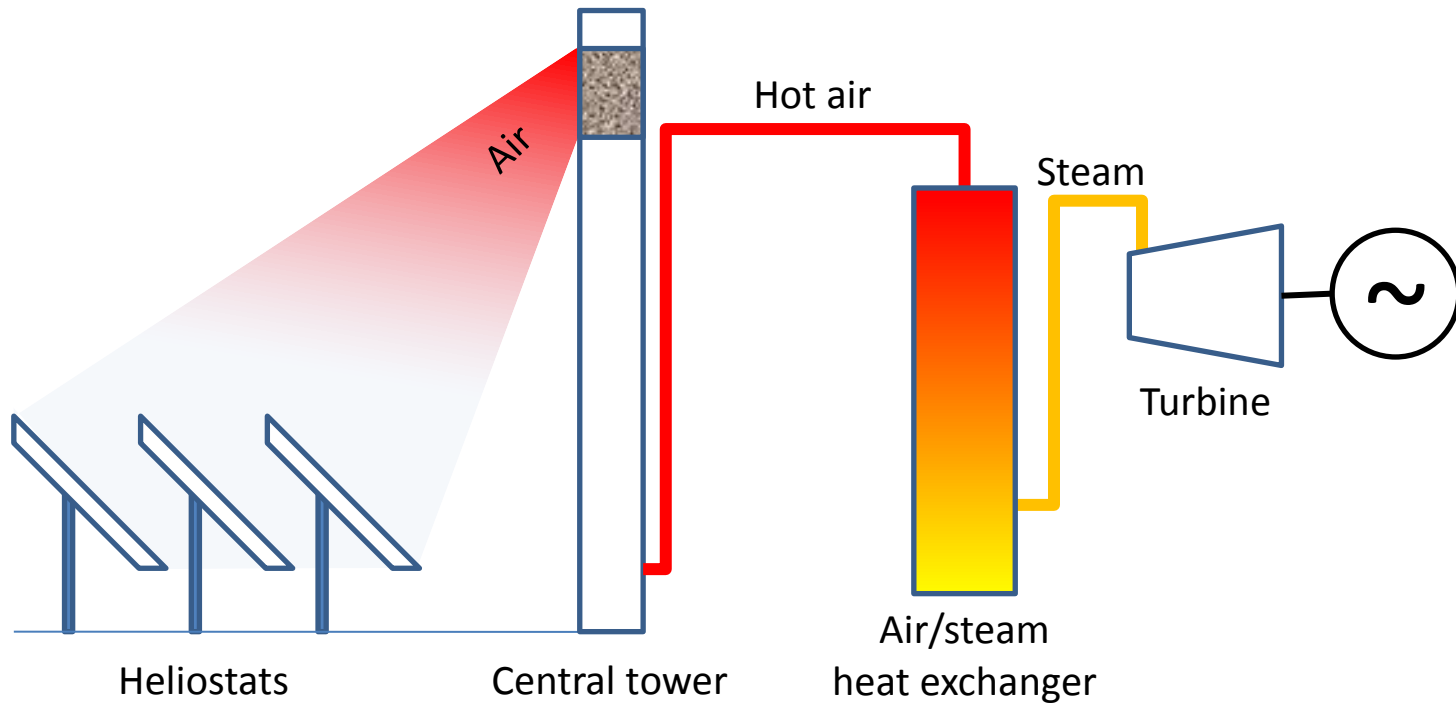

T. Fend, *Optica Applicata* 2010(Vol.40), No.2, pp. 271-284.

Concentrated solar radiation absorbers

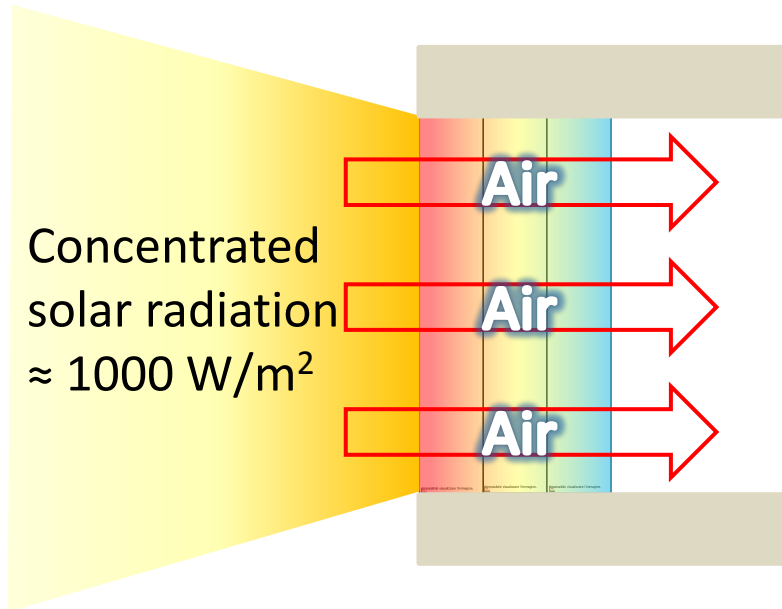

T. Fend, *Optica Applicata* 2010(Vol.40), No.2, pp. 271-284.

Concentrated solar radiation absorbers

Test efficiency measurement experimental facility

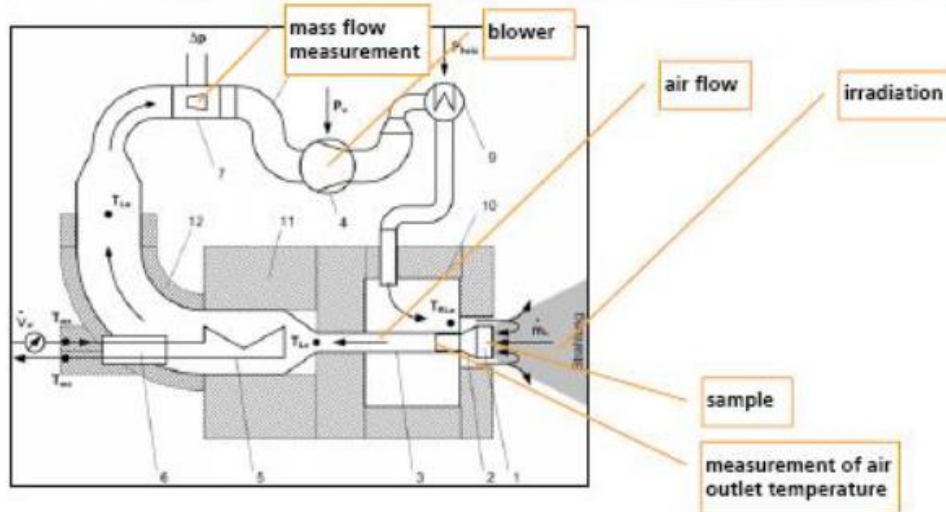

Concentrated solar radiation absorbers

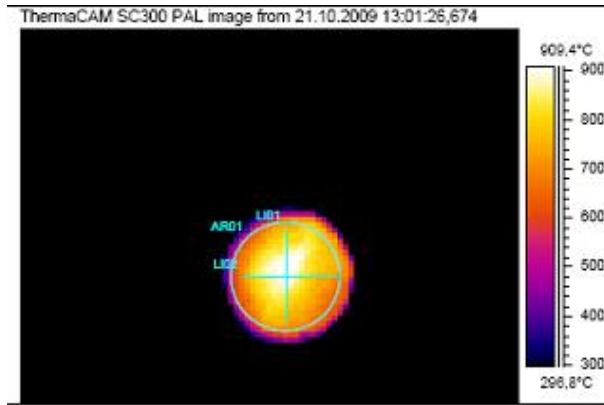

10 PPI foam

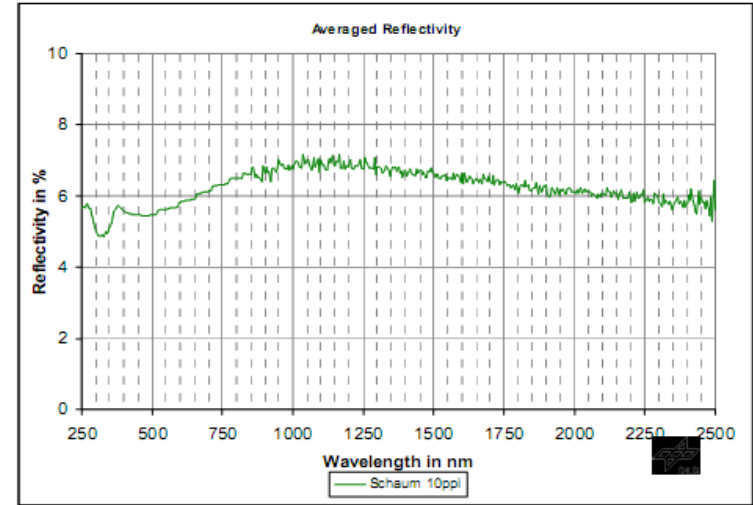

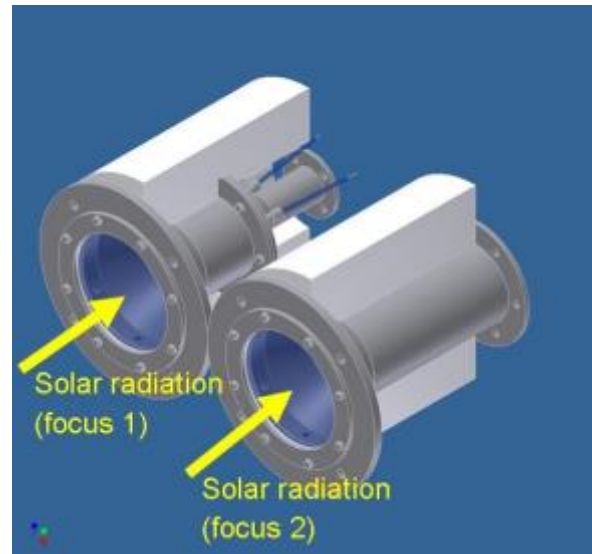

The key components, necessary for the high temperature part of the process, are a ceramic compact heat exchanger for solar or nuclear SO_3 decomposition, a receiver-reactor for solar H_2SO_4 evaporation and SO_3 decomposition and an oxygen separator.

M. Roeb et al. "HycycleS – A Project on Solar and Nuclear Hydrogen Production by Sulphur-based Thermochemical Cycles" 18th World Hydrogen Energy Conference 2010 - WHEC 2010 Parallel Sessions Book 2: Hydrogen Production Technologies Part 1 Proceedings of the WHEC, May 16.-21. 2010, Essen

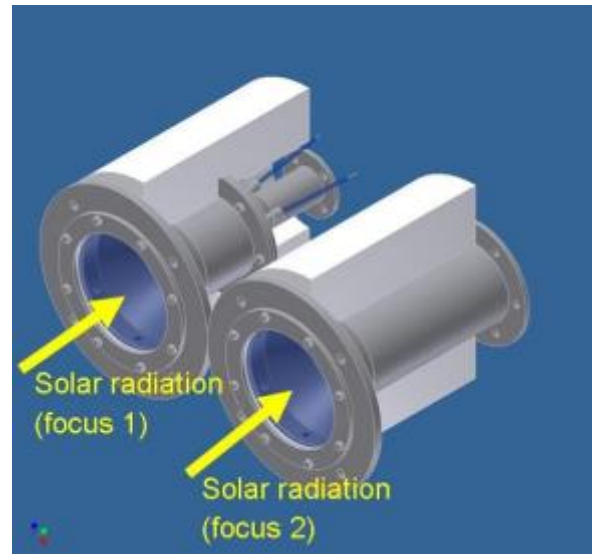

SiC based materials, withstand the conditions and keep their structural integrity over a substantial period of time (1000 hrs).

M. Roeb et al. "HycycleS – A Project on Solar and Nuclear Hydrogen Production by Sulphur-based Thermochemical Cycles" 18th World Hydrogen Energy Conference 2010 - WHEC 2010 Parallel Sessions Book 2: Hydrogen Production Technologies Part 1 Proceedings of the WHEC, May 16.-21. 2010, Essen

Cells morphology

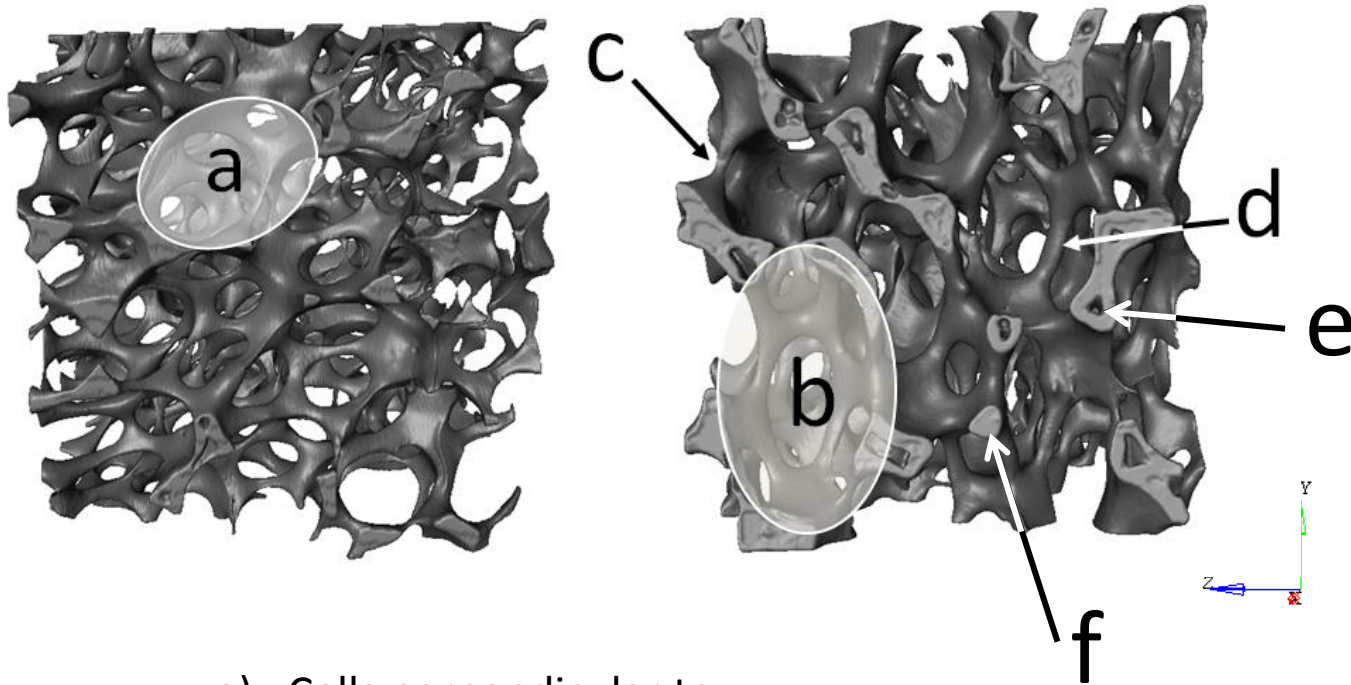

- a) Cells perpendicular to y
- b) Cell parallel to y
- c) Tapered strut
- d) Straight strut
- e) Hollow struts
- f) Full struts

What affects foams thermal conductivity?

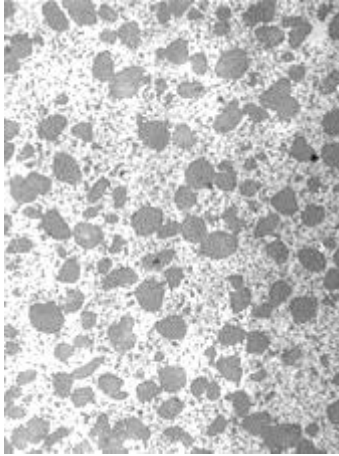

Material

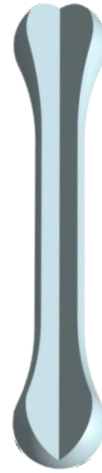
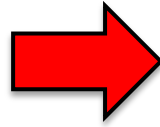



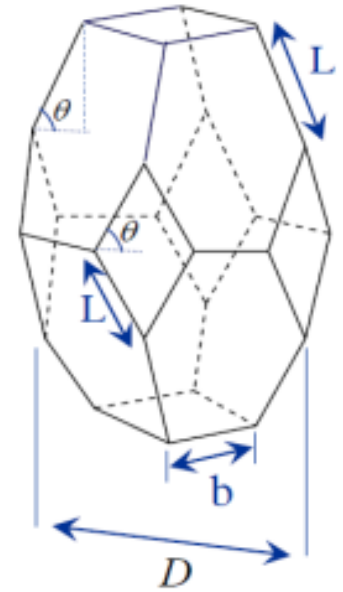
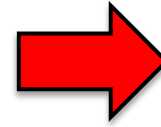



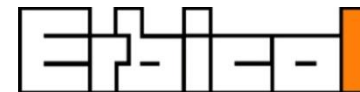

Strut



Cell



Cells parameters range

| Parameter | Min Value | Intermediate Value | Max Value |
|---------------------------------------|---|--|---|
| Cell inclination θ | 30° | 45° | 60° |
| T = 1.1 $R_{ex} = 1.5$ |  |  |  |
| Tapering T | 1 | 3 | 6 |
| $\theta = 45^\circ$ $R_{ex} = 1.5$ |  |  |  |
| R_{ex} [mm] | 0.80 | 1.25 | 1.75 |
| $\theta = 45^\circ$ T = 1.1 |  |  |  |

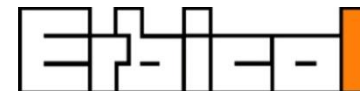

Strut thickness effect

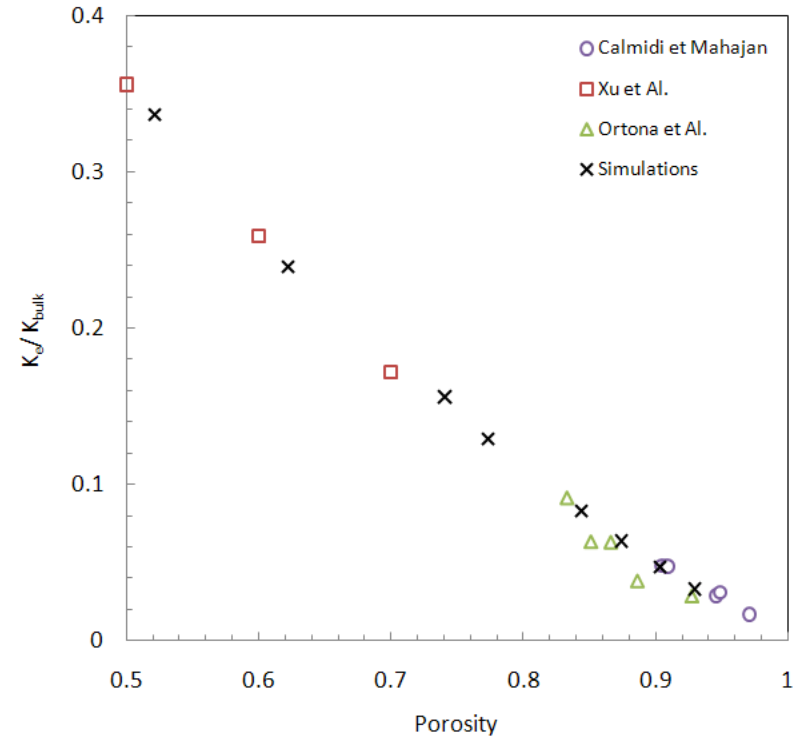
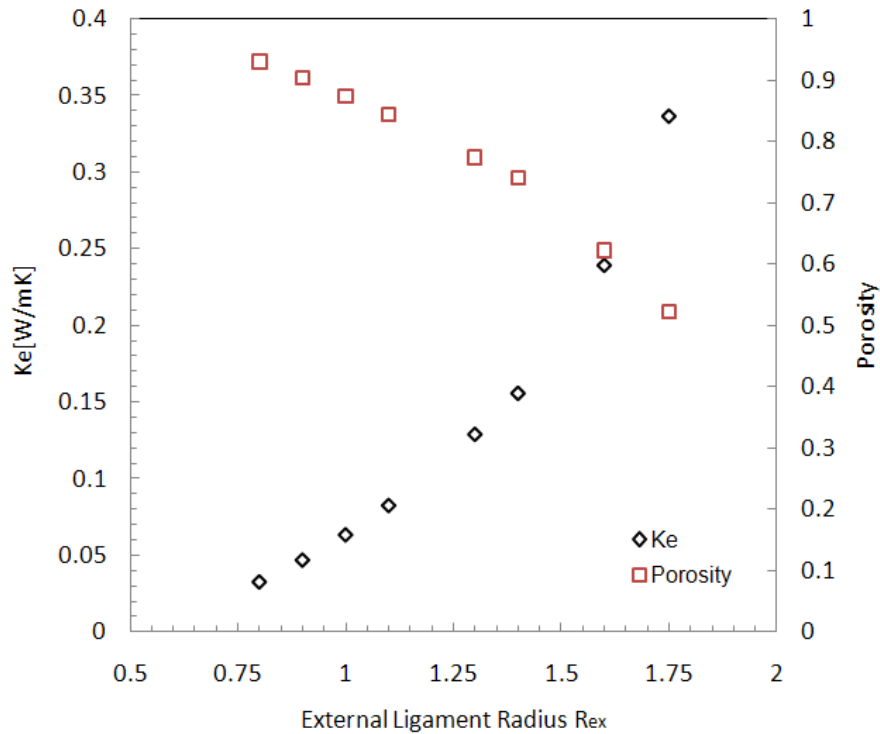

Normalized thermal conductivity variation for the increasing ligament radius R_{ex} ; cell inclination angle θ and tapering T were kept constant with values 45° and 1.1 respectively.

Hollow Vs full Struts

| Cell parameters | | | Cavity Radius | External Radius | K_{eFull} | $K_{eHollow}$ | Δ K_{eF}/k_{eH} |
|-----------------|------|----------|------------------|--------------------|-------------|---------------|-----------------------------|
| H | D | θ | | | | | |
| [mm] | [mm] | [deg.] | [mm] | [mm] | [W/mK] | [W/mK] | [%] |
| 10 | 10 | 45 | 0.5 | 0.8 | 9.86 | 5.86 | 40.5 |
| 10 | 10 | 45 | 0.5 | 1.1 | 19.73 | 13.85 | 29.7 |
| 10 | 10 | 45 | 0.5 | 1.6 | 44.48 | 36.23 | 18.5 |

Thermal conductivity variation of tetrakaydecahedra cells with hollow and full ligaments

S. Pusterla, A. Ortona, C. D'Angelo and M. Barbato, The influence of cell morphology on the effective thermal conductivity of reticulated ceramic foams, Journal of Porous Materials, 2011, DOI: 10.1007/s10934-011-9477-6

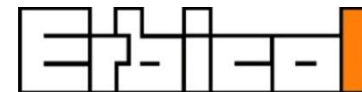

Cell parameters effect

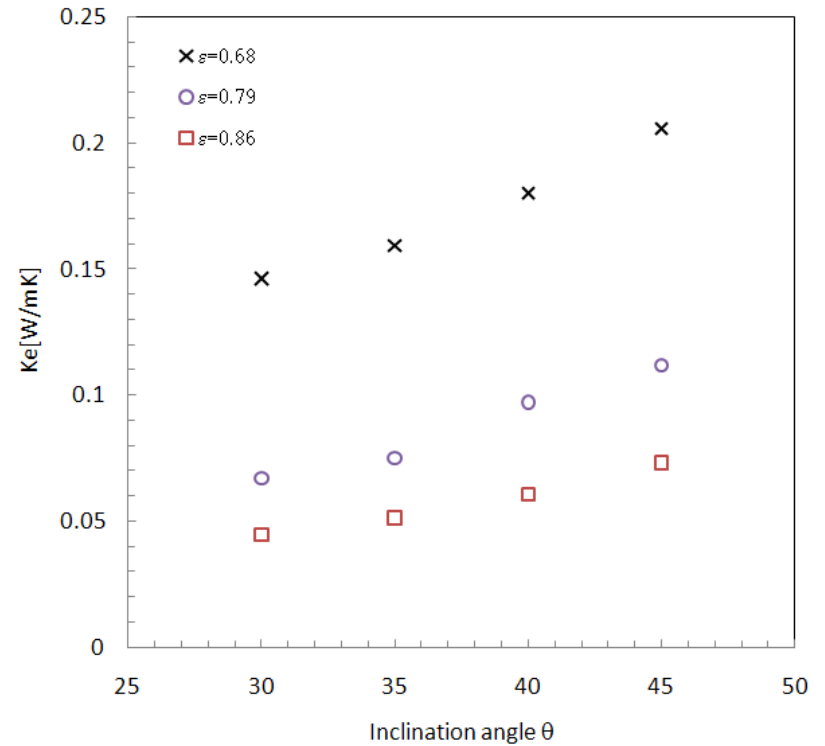
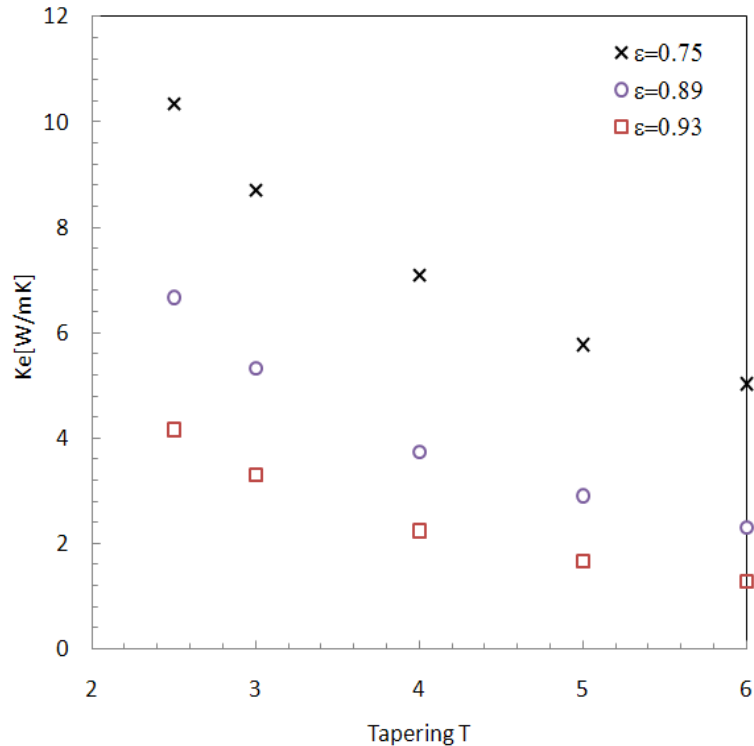

Thermal conductivity variation vs. ligament tapering T and cell inclination θ

S. Pusterla, A. Ortona, C. D'Angelo and M. Barbato, The influence of cell morphology on the effective thermal conductivity of reticulated ceramic foams, Journal of Porous Materials, 2011, DOI: 10.1007/s10934-011-9477-6

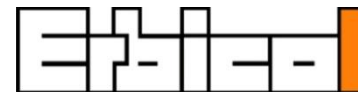

CFD Simulation results

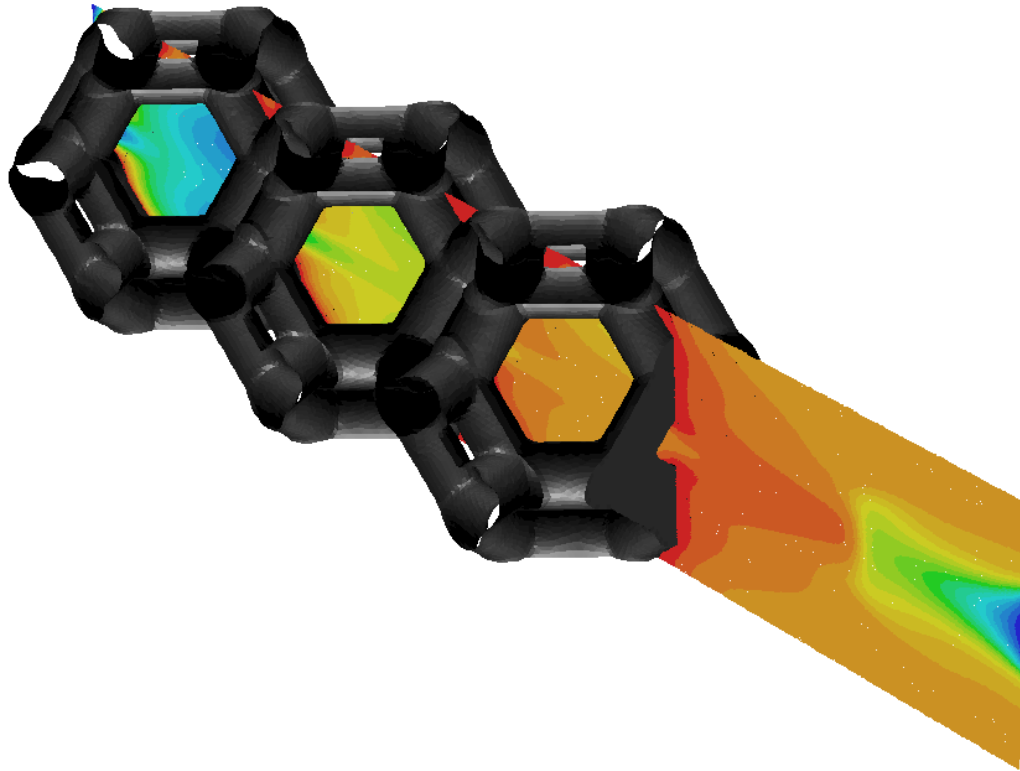

CFD Simulation results, vertical flow cross section and cell representation

FE Model and Boundary condition

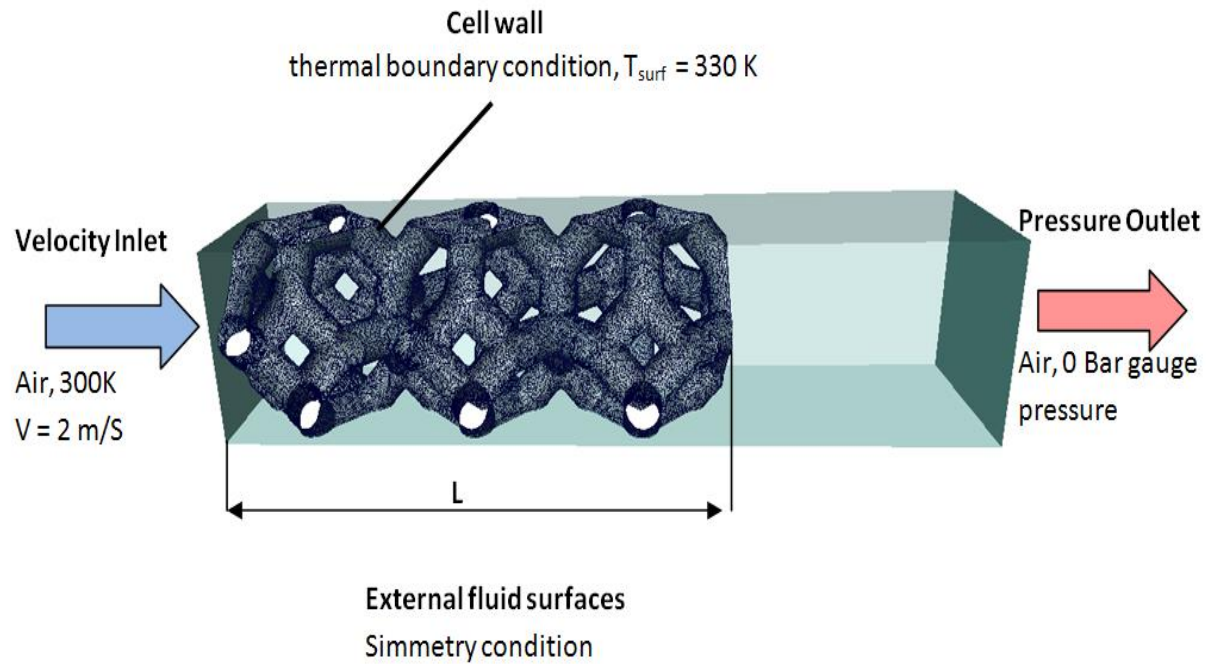

CFD Simulation results

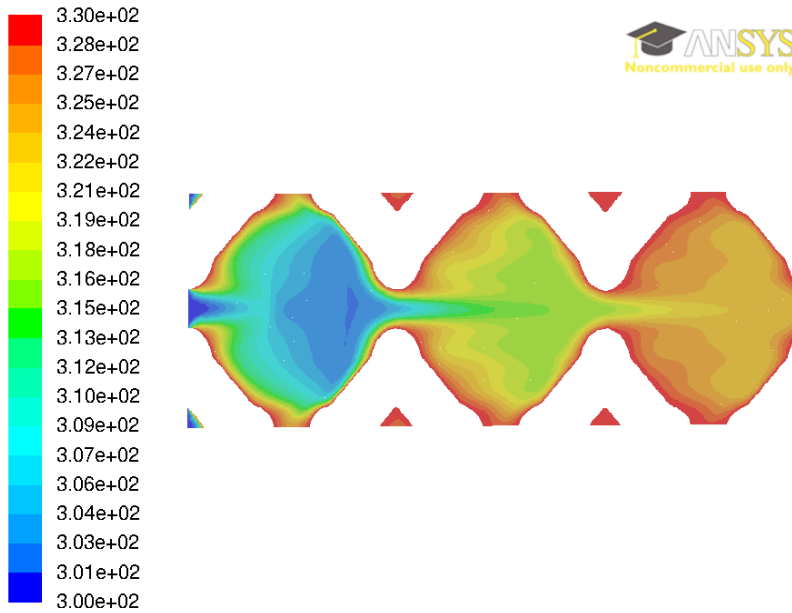

Fluid Temperature Distribution

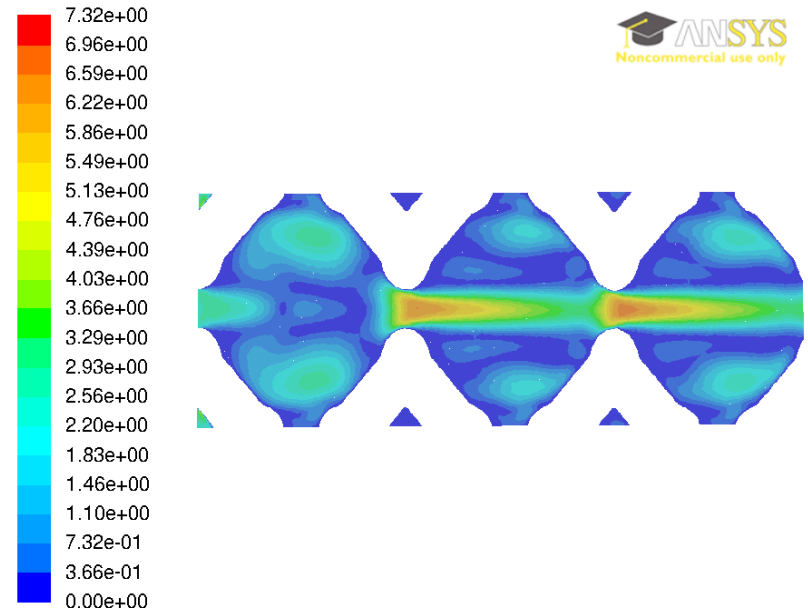

Fluid Velocity Distribution

Heat exchanger Efficiency

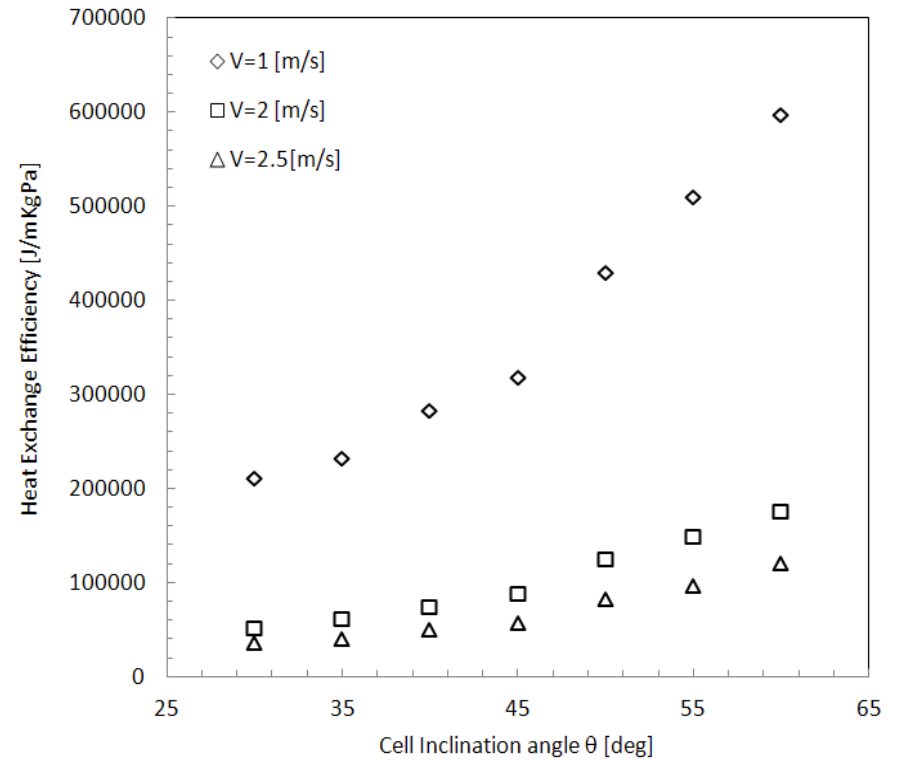
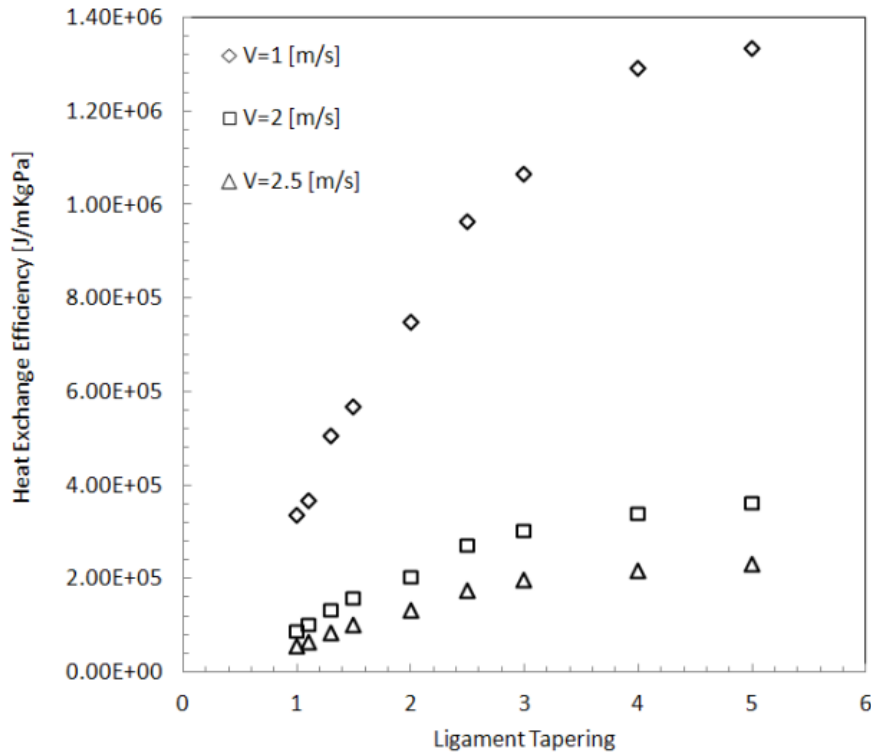

Heat exchange efficiency vs., ligament tapering T and cell incitation angle ϑ

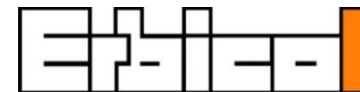

Cellular ceramics by indirect rapid prototyping

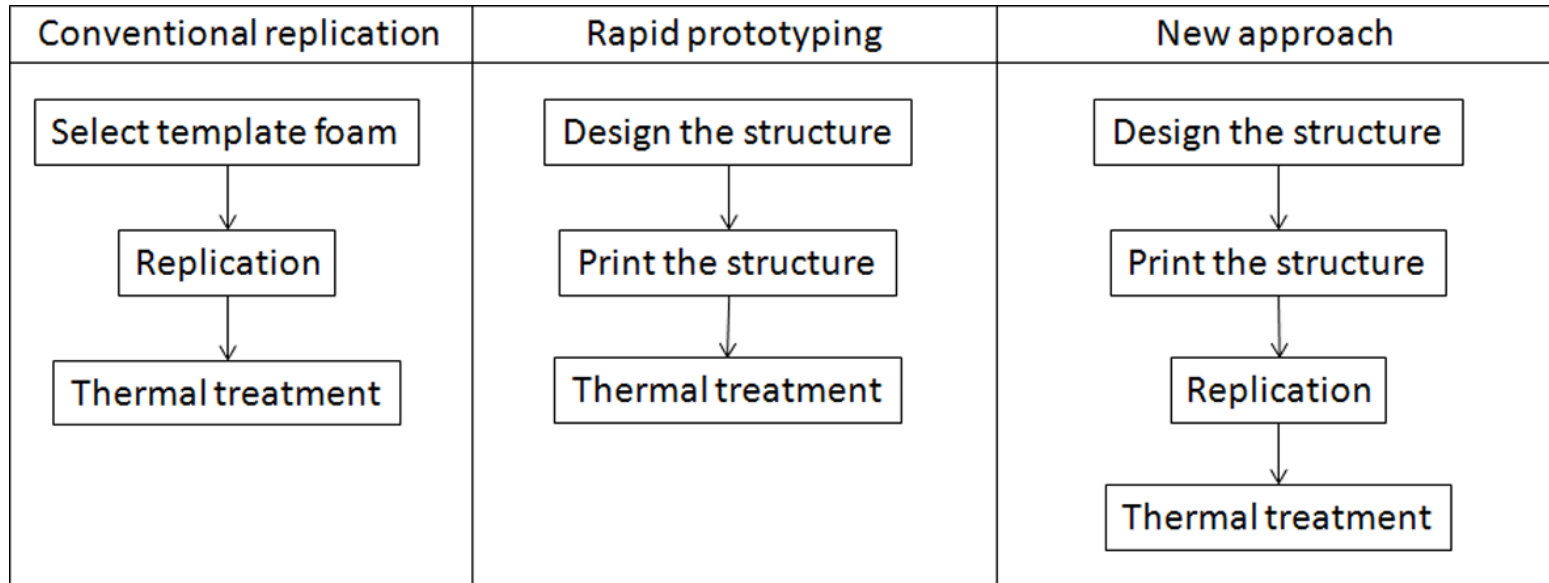

Cellular ceramics by indirect rapid prototyping

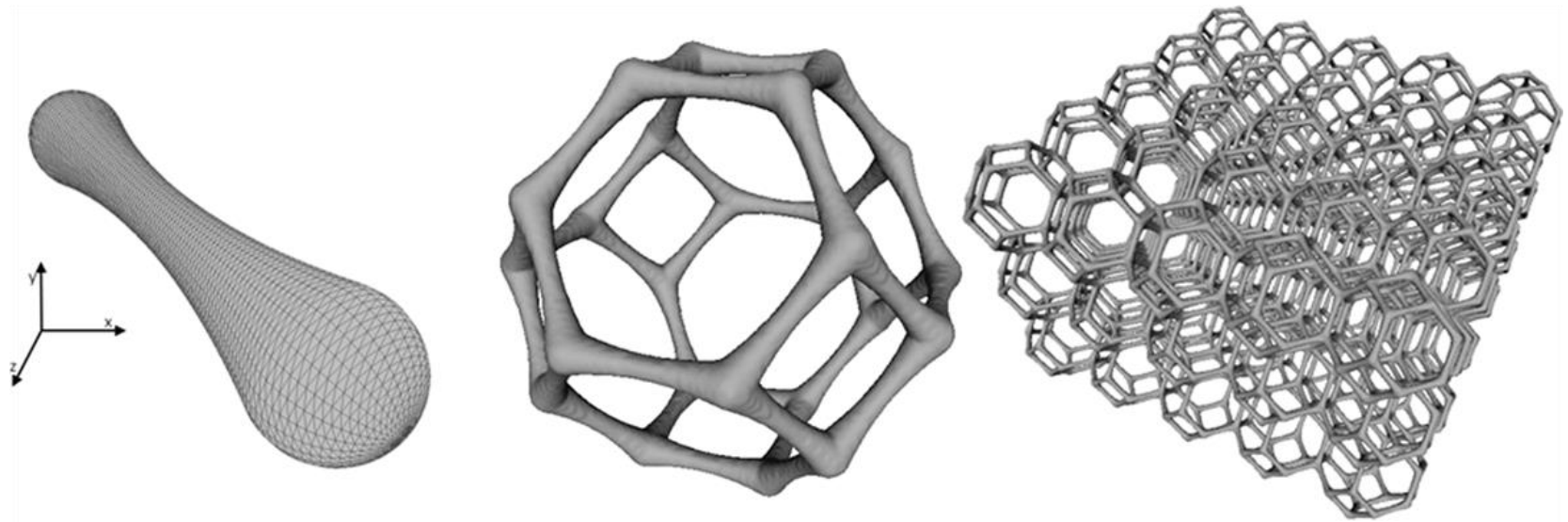

Strut

Cell

Lattice

Cellular ceramics by indirect rapid prototyping

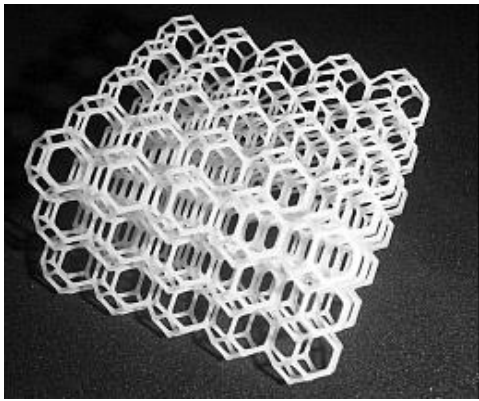

Rapid protoyping

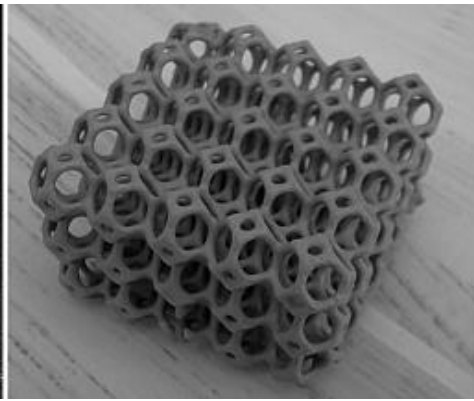

Replication



pyrolysis

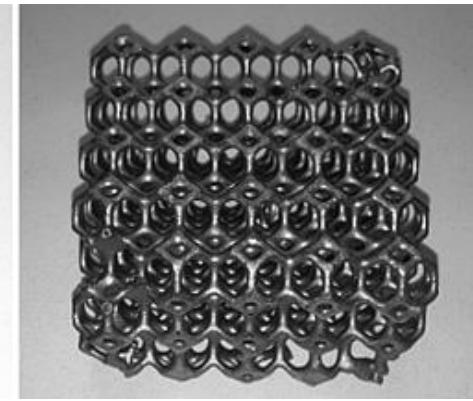

Silicon infiltration

Cellular ceramics by indirect rapid prototyping

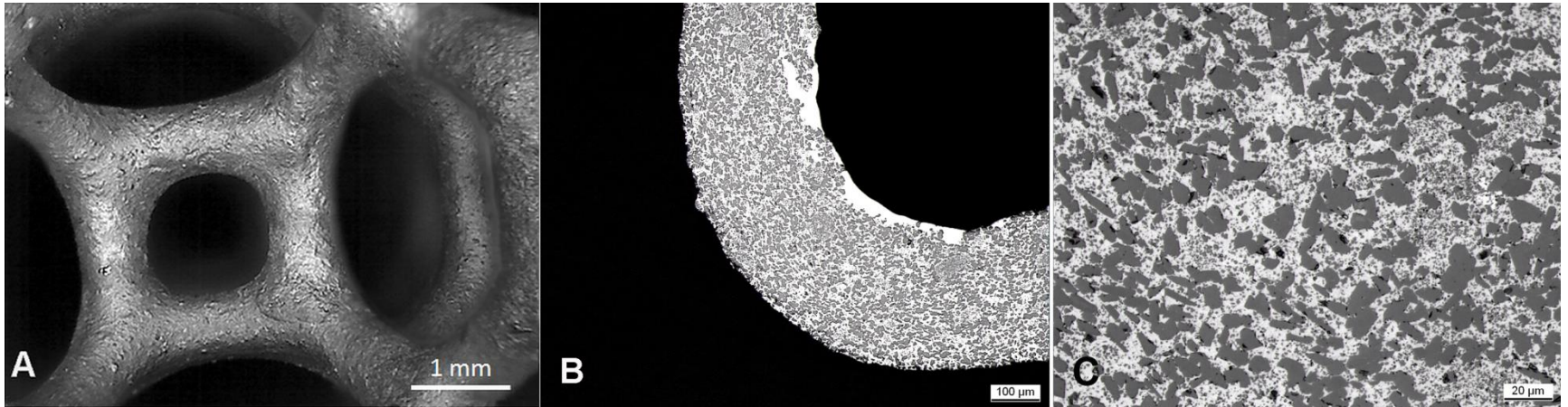

Structure at different scales

Conclusions

- Si SiC foams are a valuable solution for CSP absorbers
- There are several Si SiC foams applications
- Foams effective properties are influenced
 - mostly by foam porosity for conduction
 - by cell parameters such as cell inclination and tapering by convection
- Indirect rapid prototyping can realize engineered structures

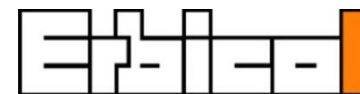

Acknowledgements

Advanced Ceramics and Composites Group at ICIMSI

Dr. ing. Giulio Scocchi

Dr. Danilo Sergi

Ing. Simone Pusterla

Ing. Claudio D'Angelo

Ing. Giovanni Bianchi

modeling

modeling

ceramic foams

composites

experiments set up

*Prof. ing. Alberto Ortona**

University of Applied Sciences (SUPSI)

The iCIMSI Research Institute,

Address:

Telephone:

alberto.ortona@supsi.ch

www.supsi.ch

www.icimsi.ch

Galleria 2, CH 6928, Manno, Switzerland

+41 58 6666611

**Contact*

